

Key Features:

- Line-array enhanced coverage control
- Organic, unobtrusive shape
- Strong-Arm-Mount for easy, flexible aiming
- Full-bandwidth overload protection
- Weather resistant and paintable
- Dual LF transducers for extended bass and greater power handling and output
- Ti direct-radiator HF transducer, Neodymium structure
- High sensitivity
- Magnetically shielded
- Zinc-plated grilles
- Transformer Versions



General Description:

The EVID 4.2 is a very compact full range loudspeaker ideal for indoor and outdoor applications requiring high-quality sound. It's shape and size make it nearly invisible for use in background/foreground music systems for restaurants, bars, patios, retail, and other applications

The 4.2's three-dimensional elliptic baffle symmetrically locates the 1" Ti high frequency element with a Coherent Coverage Waveguide in front of, and between the 4" low frequency drivers. This careful shaping, location, and 10° splaying of the lf units provides coverage control by the resulting line array. Lobing is controlled by physically "shadowing" the lf transducers from each other over the bandwidth they would normally exhibit interference. EVID's mounting system provides greater range of aiming angles in both horizontal and vertical planes than other types. The grille follows the use of curvature with designed in weather resistance and a hidden leash for safety.

All models are available in black or white, and can easily be painted to match the décor. Transformer versions are also available for constant voltage systems.

Technical Specifications:

Frequency Response ¹ (-10 dB)	65Hz - 20kHz
Power Handling ²	200 watts
Sensitivity ³	89 dB, 1W/1m
Impedance	8 ohms
Max SPL	113 dB
Horizontal Coverage ⁴	120°
Vertical Coverage ⁴	80°
Crossover Frequency	2.2 kHz
LF Transducer	2 x 4" (100 mm)
HF Transducer	1" (25 mm)
Protection	Full System
Suspension	Multi-Axis
Swing x Rotation	100° x 45°
Terminals	Spring
Enclosure Material	ABS (paintable)
"t" Version Wattage Taps	70V: 3.75 W 70V/100V: 7.5W, 15W, 30W
Dim (H x W x D)	12.2" x 6.9" x 8.5" (234 mm x 127 mm x 165 mm)
Net Weight (each)	8.5 lbs (3.9 kg)
Shipping Weight	19 lbs (8.6 kg)
Included Accessories	SAM™, hex key
¹ Half Space (wall mounting) ² Long Term Program Rating: 3 dB greater than continuous pink noise rating ³ Avg: Half Space (wall mounting) ⁴ When mounted with long axis in vertical plan	

Architecture & Engineering Specs:

The loudspeaker shall be a two-way system consisting of two 4" (102mm) low-frequency transducers, 1" (25mm) high-frequency transducer with a Coherent Coverage Waveguide, and frequency-dividing network installed in a vented, line array enclosure. The network shall include a passive limiter for both the low frequency and high frequency transducers. The loudspeaker system shall meet the following performance criteria: Power handling, 200-Watts long term program using IEC268-5 shaped pink noise; Frequency response, 65 Hz – 20 kHz (-10 dB from rated sensitivity); Pressure sensitivity, 89 dB at one watt, 200 Hz – 10 kHz at one meter; Impedance, 8 ohms nominal, 6 ohms minimum. The high frequency transducer shall drive a waveguide to evenly cover 120° horizontally by 80° vertically. The enclosure shall be molded of acrylic butyl styrene. The enclosure shall be 12.2" (310mm) high, 6.9" (175mm) wide, 8.5" (216mm) deep. The finish shall be a paintable black or white. The grille shall be zinc plated, powder coated for corrosion resistance, and restrained with a safety leash. The loudspeaker shall be adjustable over a range of 100° horizontally and 45° vertically. The support bracket shall be low profile and integral with the enclosure. The system shall be weather resistant to MIL Spec 810 and IEC 529 test conditions.

Block Diagram:

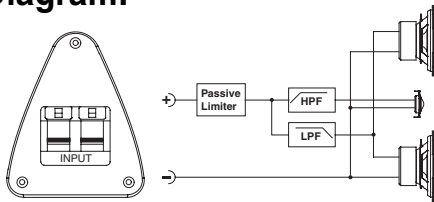

Dimension Drawings:

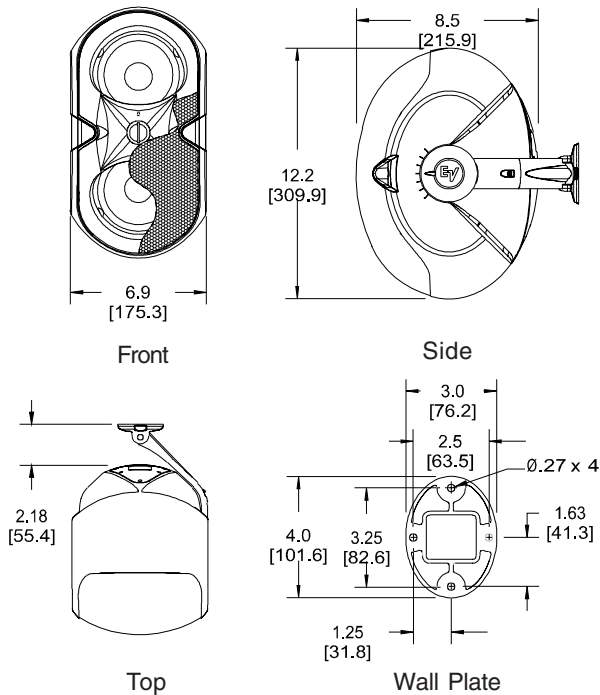

Frequency Response:

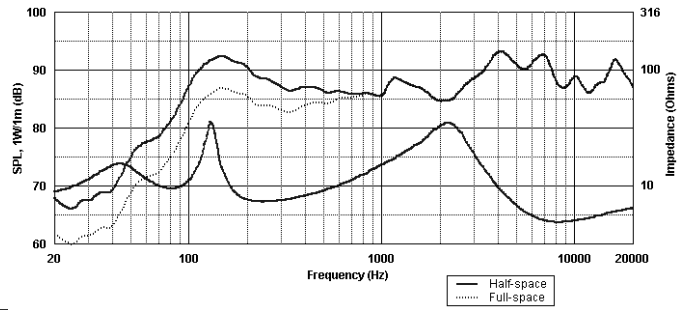

Beamwidth:

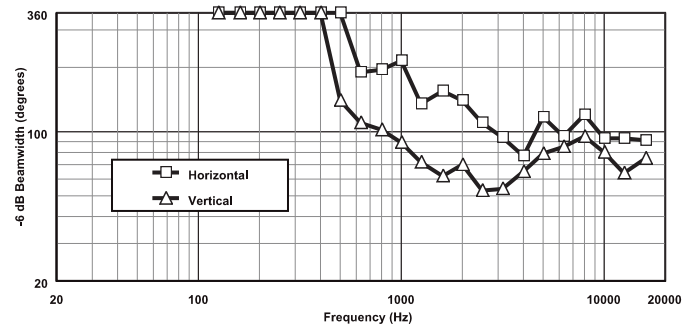

Directivity:

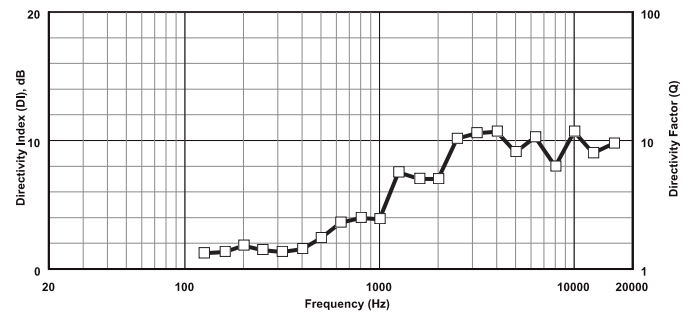

Performance Match:

- EVID 12.1 Sub

Available Accessories:

- HS-3 Horizontal Mount Desk Stand for 3.2/4.2
- VS-4 Vertical Mount Desk Stand for 4.2
- AB-62 180° Array Bracket Kit for two 4.2s Or 6.2s
- AB-64 360° Array Bracket Kit for four 4.2s Or 6.2s
- TC-4B Black Weatherized Terminal Cover for 4.2
- TC-4W White Weatherized Terminal Cover for 4.2

EVID 4.2 Part Numbers:

- 301046-001 Black
- 301046-002 White
- 301046-003 Black, Transformer
- 301046-004 White, Transformer



12000 Portland Avenue South, Burnsville, MN 55337
Phone: 952/884-4051, Fax: 952/884-0043

www.electrovoice.com

© Telex Communications, Inc. 11/2001
Part Number 38109-982 Rev B

U.S.A. and Canada only. For customer orders, contact Customer Service at:

800/392-3497 Fax: 800/955-6831

Europe, Africa, and Middle East only. For customer orders, contact Customer Service at:

+ 49 9421-706 0 Fax: + 49 9421-706 265

Other International locations. For customer orders, contact Customer Service at:

+ 1 952 884-4051 Fax: + 1 952 887-9212

For warranty repair or service information, contact the Service Repair department at:

800/685-2606

For technical assistance, contact Technical Support at: 866/78AUDIO

Specifications subject to change without notice.