



# EVENT BAR



## User Instructions

### Event Bar      General Information

**Unpacking:** Thank you for purchasing the Event Bar by Elation Professionals®. Every Event Bar has been thoroughly tested and has been shipped in perfect operating condition. Carefully check the shipping carton for damage that may have occurred during shipping. If the carton appears to be damaged, carefully inspect your fixture for any damage and be sure all equipment necessary to operate the unit has arrived intact. In the event damage has been found or parts are missing, please contact our toll free customer support number for further instructions. Please do not return this unit to your dealer without contacting customer support first.

**Introduction:** The Event Bar DMX intelligent LED fixture. The Event Bar has 3 DMX Modes; 12 Channel DMX Mode, 14 Channel Mode, and 25 Channel Mode. The fixture three operating modes; sound active mode, show mode or DMX controlled. The Event Bar can only be run as stand alone unit. This unit is suitable for theaters, studios, retail stores, and other similar locations. *For best results use fog or special effects smoke to enhance the light projections.*

**Customer Support:** Elation Professionals® provides a toll free customer support line, to provide help and to answer any question should you encounter problems during your set up or initial operation. You may also visit us on the web at [www.elationlighting.com](http://www.elationlighting.com) for any comments or suggestions. Service Hours are Monday through Friday 8:00 a.m. to 4:30 p.m. Pacific Standard Time.

Voice:           (323) 582-3322  
Fax:              (323) 832-9142  
E-mail:          support@elationlighting.com

To purchase parts online visit <http://parts.elationlighting.com>

**Warning!** To prevent or reduce the risk of electrical shock or fire, do not expose this unit to rain or moisture.

**Warning!** *This may cause severe eye damage. Avoid looking directly into the light source at all times!*

## Event Bar

## General Instructions

To optimize the performance of this product, please read these operating instructions carefully to familiarize yourself with the basic operations of this unit. These instructions contain important safety information regarding the use and maintenance of this unit. Please keep this manual with the unit, for future reference.

## Event Bar

## Features

- 3 DMX Channel Modes; 12 Channel Mode, 14 Channel Mode, & 25 Channel Mode.
- 2 Operating Modes - Show Mode, Sound Active & DMX Control
- Digital Display for Address and Function Setting
- Power Cord Daisy Chain
- Optional 12 Degree Lens Included

## Event Bar

## Warranty Registration

The Event Bar carries a 2 year (730 days) limited warranty. Please fill out the enclosed warranty card to validate your purchase and warranty. You may also register your product online at [www.elationlighting.com](http://www.elationlighting.com). All returned service items whether under warranty or not, must be freight pre-paid and accompany a return authorization (R.A.) number. If the unit is under warranty you must provide a copy of your proof of purchase invoice. Please contact Elation® customer support for a R.A. number.

## Event Bar

## Handling Precautions

**Caution!** There are no user serviceable parts inside this unit. Do not attempt any repairs yourself, doing so will void your manufacturer's warranty. In the unlikely event your unit may require service please contact Elation Professionals®.

*During operation the housing may become hot. Avoid touching the unit with bare hands while in use.*

*Elation Professionals® will not accept any liability for any resulting damages caused by the non-observance of this manual or any unauthorized modification to this unit.*

## Event Bar

## Safety Precautions

***For Your Own Personal Safety, Please Read and Understand This Manual Completely Before You Attempt To Install Or Operate This Unit!***

- To reduce the risk of electrical shock or fire, do not expose this unit rain or moisture
- Do not spill water or other liquids into or on to your unit.
- Do not attempt to operate this unit if the power cord has been frayed or broken.
- Do not attempt to remove or break off the ground prong from the electrical cord. This prong is used to reduce the risk of electrical shock and fire in case of an internal short.
- Disconnect from main power before making any type of connection.
- Do not remove the cover under any conditions. There are no user serviceable parts inside.
- Never operate this unit when it's cover is removed.
- Always be sure to mount this unit in an area that will allow proper ventilation. Allow about 6" (15cm) between this device and a wall.
- Do not attempt to operate this unit, if it becomes damaged.
- This unit is intended for indoor use only, use of this product outdoors voids all warranties.
- Always mount this unit in safe and stable matter.
- Power-supply cords should be routed so that they are not likely to be walked on or pinched by items placed upon or against them, paying particular attention to cords at plugs, convenience receptacles, and the point where they exit from the appliance.
- Cleaning -The fixture should be cleaned only as recommended by the manufacturer. See page 18 for cleaning details.
- Heat -This fixture should be situated away from heat sources such as radiators, heat registers, stoves, or other appliances (including amplifiers) that produce heat.
- The fixture should be serviced by qualified service personnel when:
  - A. Objects have fallen, or liquid has been spilled into the appliance.
  - B. The appliance has been exposed to rain or water.
  - C. The appliance does not appear to operate normally or exhibits a marked change in performance.

**Power Supply:** The Elation Professionals® Event Bar contains an automatic voltage switch, which will auto sense the voltage when it is plugged into the power source. With this switch there is no need to worry about the correct power voltage, this unit can be plugged in anywhere.

**DMX-512:** DMX is short for Digital Multiplex. This is a universal protocol used by most lighting and controller manufactures as a form of communication between intelligent fixtures and controllers. A DMX controller sends DMX data instructions from the controller to the fixture. DMX data is sent as serial data that travels from fixture to fixture via the DATA “IN” and DATA “OUT” XLR terminals located on all DMX fixtures (most controllers only have a DATA “OUT” terminal).

**DMX Linking:** DMX is a language allowing all makes and models of different manufactures to be linked together and operate from a single controller, as long as all fixtures and the controller are DMX compliant. To ensure proper DMX data transmission, when using several DMX fixtures try to use the shortest cable path possible. The order in which fixtures are connected in a DMX line does not influence the DMX addressing. For example; a fixture assigned a DMX address of 1 may be placed anywhere in a DMX line, at the beginning, at the end, or anywhere in the middle. When a fixture is assigned a DMX address of 1, the DMX controller knows to send DATA assigned to address 1 to that unit, no matter where it is located in the DMX chain.

**Data Cable (DMX Cable) Requirements (For DMX and Master/Slave Operation):** The Event Bar has 3 DMX channel modes; 12 channel mode, 14 channel mode, & 25 channel mode. The DMX address is set electronically using the controls on the rear of the unit. Your unit and your DMX controller require a approved DMX-512 110 Ohm Data cable for data input and data output. We recommend Accu-Cable DMX cables. If you are making your own cables, be sure to use standard 110-120 Ohm shielded cable (This cable may be purchased at almost all professional sound and lighting stores). Your cables should be made with a male and female XLR connector on either end of the cable. Also remember that DMX cable must be daisy chained and cannot be split.



Figure 1

**Notice:** Be sure to follow figures two and three when making your own cables. Do not use the ground lug on the XLR connector. Do not connect the cable’s shield conductor to the ground lug or allow the shield conductor to come in contact with the XLR’s outer casing. Grounding the shield could cause a short circuit and erratic behavior.

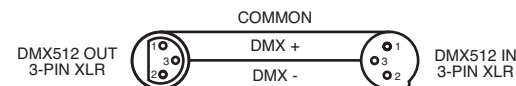

Figure 2

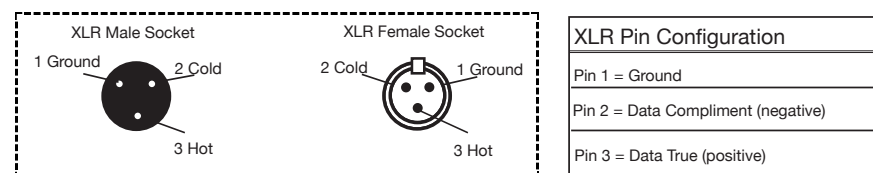

Figure 3

**Special Note: Line Termination.** When longer runs of cable are used, you may need to use a terminator on the last unit to avoid erratic behavior. A terminator is a 90-120 ohm 1/4 watt resistor which is connected between pins 2 and 3 of a male XLR connector (DATA + and DATA -). This unit is inserted in the female XLR connector of the last unit in your daisy chain to terminate the line. Using a cable terminator (ADJ part number Z-DMX/T) will decrease the possibilities of erratic behavior.



Termination reduces signal errors and avoids signal transmission problems and interference. It is always advisable to connect a DMX terminal, (Resistance 120 Ohm 1/4 W) between PIN 2 (DMX-) and PIN 3 (DMX +) of the last fixture.

Figure 4

**5-Pin XLR DMX Connectors.** Some manufactures use 5-pin XLR connectors for DATA transmission in place of 3-pin. 5-pin XLR fixtures may be implemented in a 3-pin XLR DMX line. When inserting standard 5-pin XLR connectors in to a 3-pin line a cable adaptor must be used, these adaptors are readily available at most electric stores. The chart below details a proper cable conversion.

3-Pin XLR to 5-Pin XLR Conversion		
Conductor	3-Pin XLR Female (Out)	5-Pin XLR Male (In)
Ground/Shield	Pin 1	Pin 1
Data Compliment (- signal)	Pin 2	Pin 2
Data True (+ signal)	Pin 3	Pin 3
Not Used		Pin 4 - Do Not Use
Not Used		Pin 5 - Do Not Use

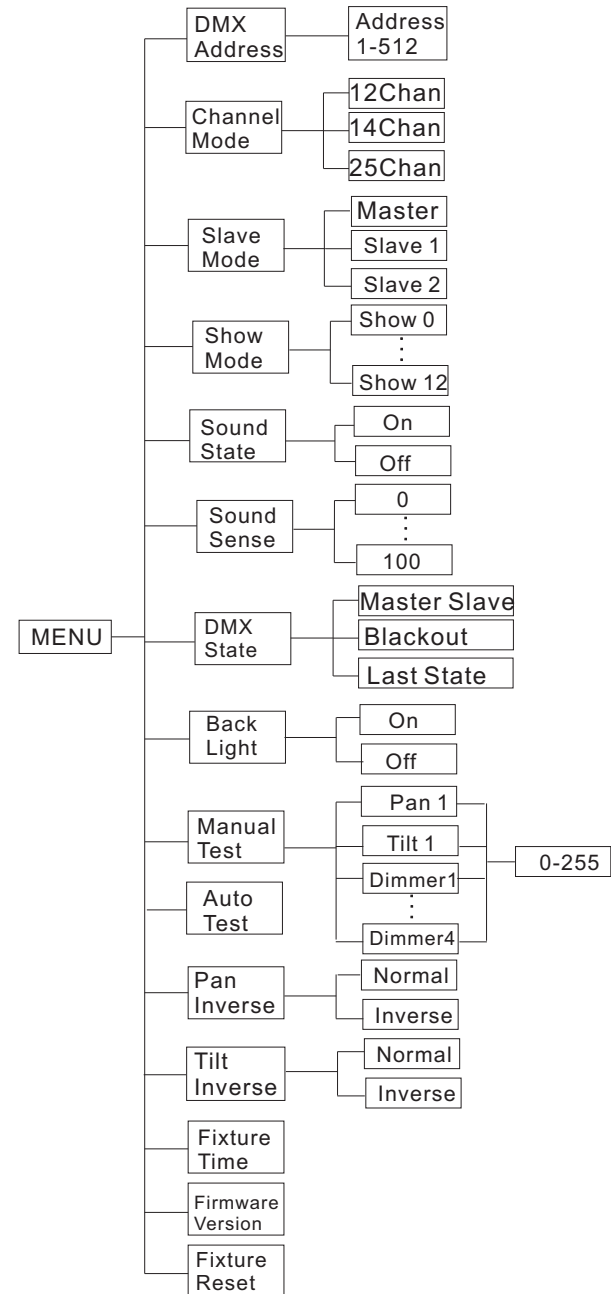

**System Menu.** The Event Bar comes with an easy to navigate system menu. This next section will detail the functions of each command in the system menu. ***Please read the next section thoroughly!***

To access the main menu press the MENU button. Tap the UP or DOWN buttons until you reach function you wish to change. When you reach the function you wish to change press the ENTER button. When a function is selected use the UP or DOWN buttons to change the function settings. Once your changes are made press the ENTER button, and then press and hold the MENU button for at least three seconds to confirm and lock the change into the system memory. If the MENU button is not pressed and held within eight seconds the fixture will automatically confirm and lock the change into the system memory. To exit without making any changes press the MENU button.

### **DMX Address - Set the DMX Address**

1. First set the unit to your desired DMX Channel mode.
2. To set your address, tap either the MENU, UP, or DOWN buttons until “DMX Address” is displayed, press ENTER. “1” will now be displayed and flashing.
3. Press the UP or DOWN buttons to find your desired address. When you have found your desired DMX address press ENTER, and connect your DMX Controller. Then press and hold MENU for 3 seconds to activate DMX control.

### **Channel Mode - This will let you switch between the 3 DMX Channel Modes.**

1. Press the MENU button until “Channel Mode” is displayed, press ENTER. Either 12 Channel Mode, 14 Channel Mode, or 25 Channel Mode will be displayed.
2. Press the UP or DOWN buttons to choose your desired DMX mode and press ENTER to confirm and exit.

### **Slave Mode - This will let you set the unit as a master or slave in a master/slave configuration.**

1. Press the MENU button until “Slave Mode” is displayed,

press ENTER. Either Master, Slave 1, or Slave 2 will be displayed.

2. Press the UP or DOWN buttons until your desired setting is displayed, press ENTER to confirm.

**NOTE:** In a Master/Slave configuration you can set one fixture to Master and then set the next fixture to Slave 2, the fixtures will now have contrast movement to each other.

### **Show Mode - Show modes 0-12 (Factory Installed Shows). This will let you choose one of the 12 preprogrammed shows. You can run show mode with sound active mode on or off.**

1. Press the MENU button until “Show Mode” is displayed, press ENTER.
2. “Show X” will now be displayed, “X” representing a number between 0-12. Shows 1-12 are factory installed shows, while “Show 0” is random mode. Press the UP or DOWN buttons to find your desired show and press the ENTER, then press and hold the MENU button for at least 3 seconds to activate your selected show.

### **Sound State - Sound Active mode.**

1. Press the MENU button until “Sound State” is displayed, press ENTER.
2. The display will show either ON or OFF. Press the UP or DOWN buttons to select ON to activate sound active mode, or OFF to deactivate sound active mode.
3. Press ENTER to confirm, then press and hold the MENU button for at least 3 seconds to activate sound active mode.

### **Sound Sense - In this mode you can adjust the sound sensitivity of the sound active mode.**

1. Press the MENU button until “Sound Sense” is displayed,

press ENTER.

2. Press the UP or DOWN buttons to adjust the sensitivity level. The sensitivity level can be adjusted between 0 (the lowest) and 100 (most sensitive).
3. Press ENTER to set you desired level.

**DMX State - This mode can be used as a precaution mode, that in case the DMX signal is lost, the operating mode chosen in the setup is the running mode the fixture will go into when the DMX signal is lost. You can also set this as the operating mode you would like the unit to return to when power is applied.**

1. Press the MENU button until “DMX State” is displayed, press ENTER.
2. Either “Master Slave”, “Blackout”, or “Last State” will be displayed. Choose an operating mode you would like the unit to start up in when power is applied or the DMX signal is lost.
  - Master Slave - If the DMX signal is lost or power is applied, the unit will automatically go into Master Slave mode.
  - Blackout - If the DMX signal is lost or power is applied, the unit will automatically go into stand by mode.
  - Last State - If the DMX signal is lost the fixture will stay in the last DMX set up. If power is applied and this mode is set, the unit will automatically go into the last DMX set up.
3. Press ENTER to confirm your desired set up.

**Back Light - With this function you can have the LED display turn off after 20 seconds.**

1. Press the MENU button until “Back Light” is displayed, press ENTER.
2. The display will show either “ON” or “OFF”. Press the UP or DOWN buttons to select “ON” to keep the LED display On at all

times, or “OFF” so that the LED display turns off after 20 seconds.

3. Press ENTER to confirm.

**Manual Test - This function will let you manually test the pan, tilt, & dimmer of each light.**

1. Press the MENU button until “Manual Test” is displayed, press ENTER.
2. Use the UP and DOWN buttons to test the four lights. To exit manual test press either the MENU or ENTER button.

**Auto Test - This function will run a self test program.**

1. Press the MENU button until “Auto Test” is displayed, press ENTER.
2. The fixture will now run a self test program. To stop the self test press the MENU button.

**Pan Inverse**

1. Press the MENU button until “Pan Inverse” is displayed, press ENTER. Either “Inverse” or “Normal” will be displayed.
2. To activate the Pan inversion tap the UP or DOWN buttons until “Inverse” is displayed, press ENTER to confirm. To deactivate Pan inversion, select “Normal” and press Enter.

**Tilt Inverse**

1. Press the MENU button until “Tilt Inverse” is displayed, press ENTER. Either “Inverse” or “Normal” will be displayed.
2. To activate the Pan inversion tap the UP or DOWN buttons until “Inverse” is displayed, press ENTER to confirm. To deactivate Pan inversion, select “Normal” and press Enter.

**Fixture Time - With this function you can display the run-**

**ning time of the unit.**

1. Press the MENU button until “Fixture Time” is displayed, press ENTER.
2. The display shows the running time of the unit. Press MENU to exit.

**Firmware Version - Use this function to display the Firmware version of the unit.**

1. Press the MENU button until “Firmware Version” is displayed, press ENTER.
2. The display will show the software version. Press MENU to exit.

**Fixture Reset - Use this function to reset the unit.**

1. Tap the MENU button until “Fixture Reset” is displayed, press ENTER.
2. The fixture will now reset.

**With this function you can adjust and set the fixtures home position.**

1. Press the ENTER button for at least 5 seconds to enter into offset mode.
2. Press the UP or DOWN buttons until “Offset” is displayed, and press ENTER. The display will begin to flash.
3. Press the UP or DOWN buttons to adjust to your desired home position. Once you have found your desired position press the ENTER button to set and save, or press the MENU button to return to return to offset functions without any changes. If you do not press any buttons for 8 seconds the fixture will return to the offset functions automatically.

**Universal DMX Control:** This function allows you to use a Elation® universal DMX-512 controller to create unique programs tailored to your individual needs.

1. The Event Bar has three DMX channel modes. To set the DMX channel mode see page 10. See pages 15-16 for the DMX modes & traits.
2. To control your fixture in DMX mode, follow the set-up procedures on pages 5-7 as well as the set-up specifications that are included with your DMX controller.
3. Use the controller’s faders to control the various DMX fixture traits.
4. This will allow you to create your own programs.
5. Follow the instructions on page 10 to set the DMX address.
6. For longer cable runs (more than a 100 feet) use a terminator on the last fixture.
7. For help operating in DMX mode consult the manual included with your DMX controller.

Stand by	Blackout the unit		
Function	1. Synchronous Strobe 2. Two light Strobe 3. Sound Control	Select Show 1-11	Select Speed 1.Fast 2.Middle 3.Slow
Mode	Strobe (LED OFF)	Chase (LED ON)	LED blinking

## Event Bar 12 Channel Mode

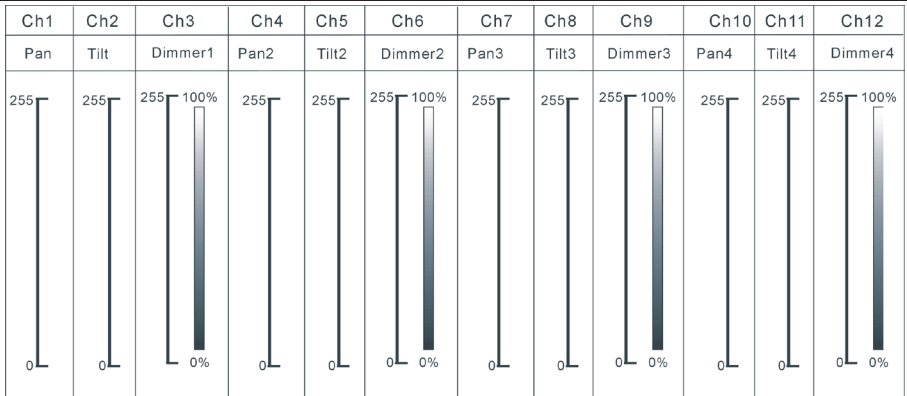

## Event Bar 14 Channel Mode

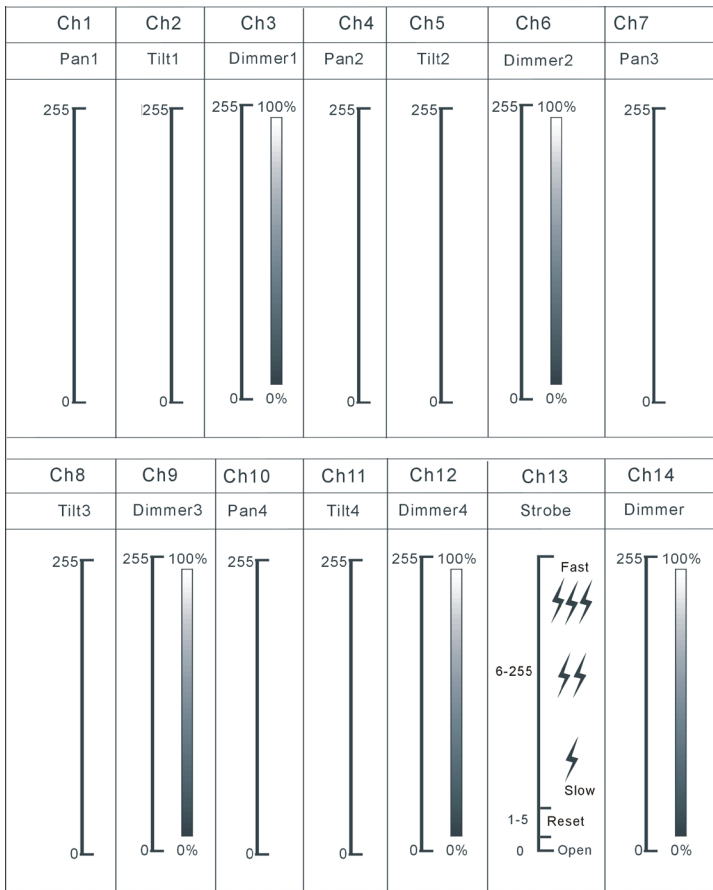

## Event Bar 25 Channel Mode

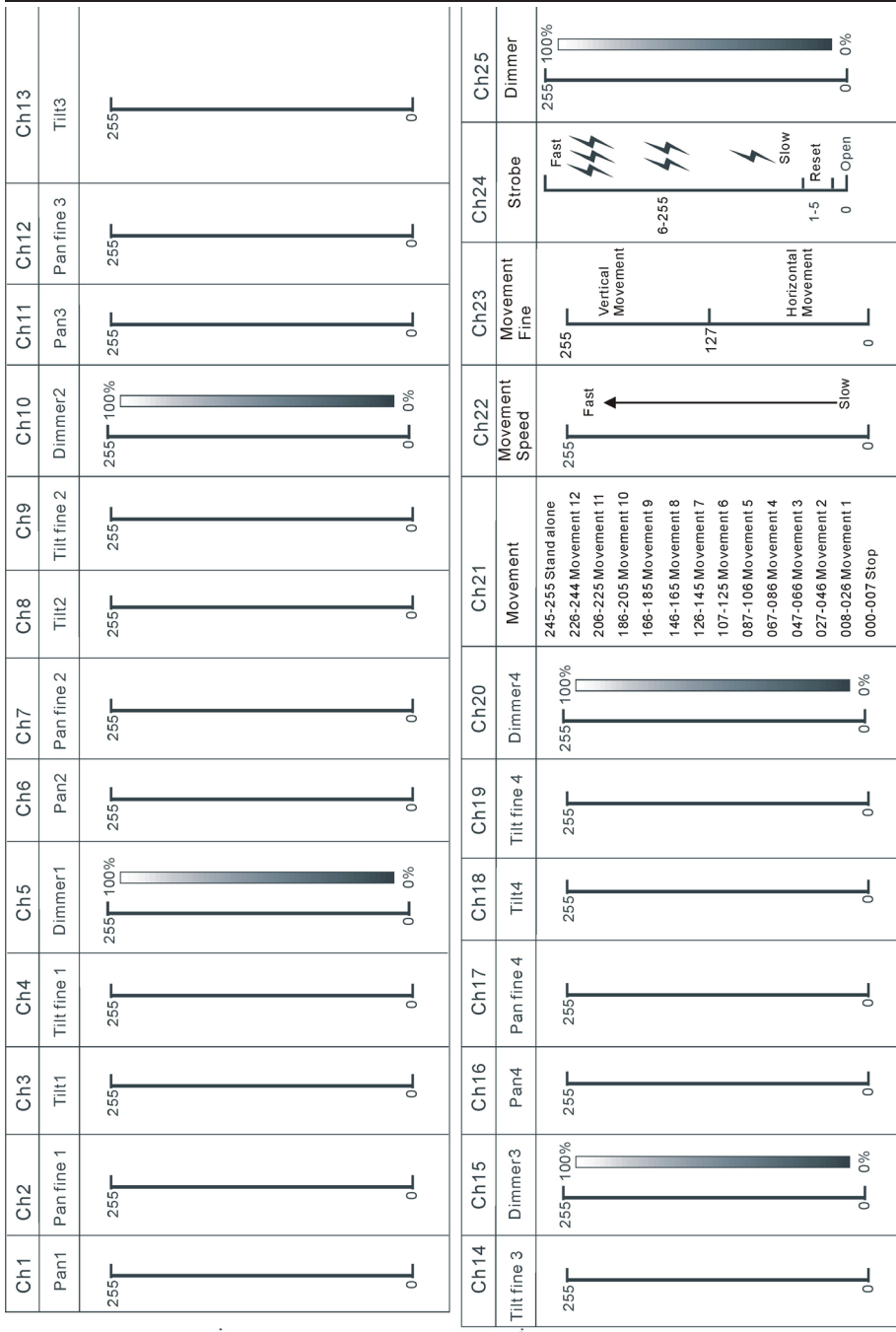



## Event Bar

## Changing Lenses

The Event Bar comes with a standard 6 degree lens already attached. Included in the box is an optional 12 degree lens. To switch lenses simply remove the retainer ring in front of the current lens, carefully remove the lens, and attach the 12 degree lens. Replace the retainer ring and the switch is complete.

## Event Bar

## Power Cord Daisy Chain

***With this feature you can connect the fixtures to one another using the IEC input and output sockets. The quantity that can be connected is 4 fixtures maximum. After 4 fixtures you will need to use a new power outlet. They must be the same fixtures. DO NOT mix fixtures.***

## Event Bar

## Installation

The Event Bar is fully operational in three different mounting positions, hanging upside-down from a ceiling, hanging sideways on trussing, or set on a flat level surface. The unit should be mounted using a mounting clamp (not provided), affixing it to the mounting bracket that is provided with the unit. Always ensure that the unit is firmly fixed to avoid vibration and slipping while operating. Always ensure that the structure to which you are attaching the unit is secure and is able to support a weight of 10 times the unit's weight. Also, always use a safety cable that can hold 12 times the weight of the unit when installing the fixture.

The equipment must be installed by a professional, and it must be installed in a place where it is out of the reach of people's grasp.

## Event Bar

## Fuse Replacement

First unplug the power. Locate and remove the unit's power cord. Once the cord has been removed locate the fuse holder located inside the power socket. Insert a flat-head screw driver into the power socket and gently pry out the fuse holder. Remove the bad fuse and replace with a new one. The fuse holder has a built-in socket for a spare fuse be sure not to confuse the spare fuse with active fuse.

## Event Bar

## Cleaning

**Fixture Cleaning:** Due to fog residue, smoke, and dust cleaning the internal and external optical lenses and mirror should be carried out periodically to optimize light output. Cleaning frequency depends on the environment in which the fixture operates (I.e. smoke, fog residue, dust, dew). In heavy club use we recommend cleaning on a monthly basis. Periodic cleaning will ensure longevity, and crisp output.

1. Use normal glass cleaner and a soft cloth to wipe down the outside casing.
2. Use a brush to wipe down the cooling vents and fan grill.
3. Clean the external optics and mirror with glass cleaner and a soft cloth every 20 days.
4. Clean the internal optics with glass cleaner and a soft cloth every 30-60 days.
5. Always be sure to dry all parts completely before plugging the unit back in.

## Event Bar

## Trouble Shooting

**Trouble Shooting:** Listed below are a few common problems that you may encounter, with solutions.

### ***No light output from the unit;***

1. Be sure the external fuse has not blown. The fuse is located on the rear panel of the unit.
2. Be sure the fuse holder is completely and properly seated.

**Event Bar****Warranty****2-YEAR LIMITED WARRANTY**

A. Elation® Architectural hereby warrants, to the original purchaser, Elation® Professionals® products to be free of manufacturing defects in material and workmanship for a period of two years (730 days) from the date of purchase. This warranty shall be valid only if the product is purchased within the United States of America, including possessions and territories. It is the owner's responsibility to establish the date and place of purchase by acceptable evidence, at the time service is sought.

B. For warranty service, send the product only to the Elation® Professionals® factory. All shipping charges must be pre-paid. If the requested repairs or service (including parts replacement) are within the terms of this warranty, Elation® Professionals® will pay return shipping charges only to a designated point within the United States. If the entire instrument is sent, it must be shipped in its original package. No accessories should be shipped with the product. If any accessories are shipped with the product, Elation® Professionals® shall have no liability whatsoever for loss of or damage to any such accessories, nor for the safe return thereof.

C. This warranty is void if the serial number has been altered or removed; if the product is modified in any manner which Elation® Professionals® concludes, after inspection, affects the reliability of the product; if the product has been repaired or serviced by anyone other than the Elation® Professionals® factory unless prior written authorization was issued to purchaser by Elation® Professionals®; if the product is damaged because not properly maintained as set forth in the instruction manual.

D. This is not a service contract, and this warranty does not include maintenance, cleaning or periodic check-up. During the period specified above, Elation® Professionals® will replace defective parts at its expense, and will absorb all expenses for warranty service and repair labor by reason of defects in material or workmanship. The sole responsibility of Elation® Professionals® under this warranty shall be limited to the repair of the product, or replacement thereof, including parts, at the sole discretion of Elation® Professionals®. All products covered by this warranty were manufactured after January 1, 1990, and bear identifying marks to that effect.

E. Elation® Professionals® reserves the right to make changes in design and/or improvements upon its products without any obligation to include these changes in any products theretofore manufactured.

F. No warranty, whether expressed or implied, is given or made with respect to any accessory supplied with products described above. Except to the extent prohibited by applicable law, all implied warranties made by Elation® Professionals® in connection with this product, including warranties of merchantability or fitness, are limited in duration to the warranty period set forth above. And no warranties, whether expressed or implied, including warranties of merchantability or fitness, shall apply to this product after said period has expired. The consumer's and or Dealer's sole remedy shall be such repair or replacement as is expressly provided above; and under no circumstances shall Elation® Professionals® be liable for any loss or damage, direct or consequential, arising out of the use of, or inability to use, this product.

G. This warranty is the only written warranty applicable to Elation® Professionals® Products and supersedes all prior warranties and written descriptions of warranty terms and conditions heretofore published.

**Event Bar****Specifications**

<b>Model:</b>	<b>Event Bar</b>
<b>Voltage:</b>	100~240V, 50/60Hz
<b>LEDs:</b>	4 x 3W White LEDs
<b>Beam Angle:</b>	6 Degrees (Optional 12 Degree Lens)
<b>Power Consumption:</b>	54W
<b>Fuse:</b>	7A
<b>Power Cord Daisy Chain:</b>	4 Fixtures Max.
<b>Dimensions:</b>	39"(L) x 3"(W) x 8"(H) 1000mm x 80mm x 202mm
<b>Weight:</b>	16.8 Lbs. / 7.6 kgs.
<b>Colors:</b>	White
<b>Duty Cycle:</b>	None
<b>DMX:</b>	3 DMX Channel Modes: 12 Channel Mode, 14 Channel Mode, & 25 Channel Mode
<b>Sound Active:</b>	Yes
<b>Working Position:</b>	Any Safe, Secure Position
<b>Warranty:</b>	2 Year (730 days)

**Please Note:** Specifications and improvements in the design of this unit and this manual are subject to change without any prior written notice.

**Auto Sensing Voltage:** This fixture contains a automatic voltage switch, which will auto sense the voltage when it is plugged into the power source.

©Elation Professionals®

A Division of the AmericanDJ® Group of Companies

World Headquarters:

6122 S. Eastern Ave. Los Angeles, CA 90040 USA

Tel: 323-582-3322 Fax: 323-832-9142

Web: www.elationlighting.com E-mail: info@elationlighting.com

American DJ Europe

Junostraat 2

6468 EW Kerkrade

Netherlands

service@adjgroup.eu / www.americandj.eu

Tel: +31 45 546 85 00 / Fax: +31 45 546 85 99